

DIGIFIZmini wiring diagrams Exhaust Gas Temperature

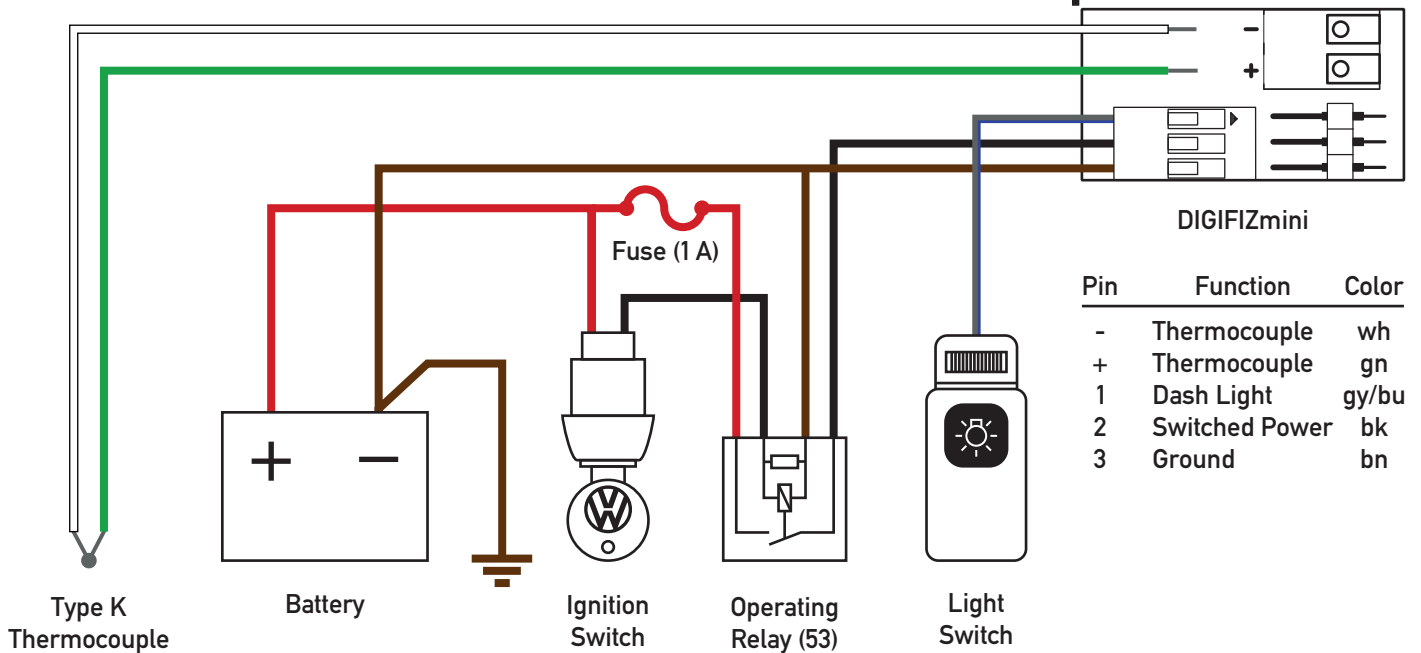

Installation Notes:

- DIGIFIZminis are not plug and play devices
- Installation should only be done by experienced personnel
- Disconnect the battery before doing any work to vehicle electronics
- One relay and one fuse are enough for up to ten DIGIFIZminis
- Don't connect power in reverse, it might kill your DIGIFIZmini
- Crimping wires should always be preferred to soldering
- The clamping force of the terminal block for the thermocouple contact is limited. It is recommended to secure the thermocouple wiring additionally, i.e. by zip-tying it to the DIGIFIZmini harness
- Supported sensor: Type K thermocouple